

Genetics Unit: Study Guide

Things to Study:

- A) NOTES (DNA Replication/ Mutation, & Genetics)
 B) BTRs 46 - 64

1. Inherited Disease Review: Match each of the lettered choices below to its appropriate box in the table below

Inherited Disease	Causes	Symptoms	Treatments/Cures
Muscular Dystrophy MD			
Huntington Disease HD			
Cystic Fibrosis CF			
Sickle-cell Anemia SCA			
Xeroderma Pigmentosa XP			

- A = Happens when 2 recessive mutations are inherited.
 B = Happens when 1 (or 2) dominant mutations are inherited
 C = Happens when 1 recessive mutation is inherited in boys
 D = Patients improve after blood transfusions of healthy blood cells
 E = Gradual brain deterioration leads to slurred speech uncontrolled "jerky" chorea movements
 F = Broken repair enzymes leads to accumulation of DNA damage from UV light exposure
 G = Patients may improve muscle growth and function after Prednisone steroid treatments
 H = Thick, dry mucus in the lungs leads to coughing and frequent lung infections
 I = Patients improve brain function after implanting healthy brain cells from aborted human fetuses or pigs embryos
 J = Patients have chronic fatigue and blood clots, strokes, pain, and organ damage due to blocked capillaries.
 K = Treatments help patients make healthy blood cells after surgical transplants of bone marrow or stem cells from umbilical cords.
 L = Patients use medicated inhalers and receive daily "drumming" therapy when young or later the Airaply vest
 M = Progressive loss of muscle function leading to wheelchair use when young
 N = Patients wear UV-protective "space suits" and use lotion with working repair enzymes
 O = Gene Therapy is being tested to deliver correct DNA genes to cells with nonfunctional proteins
 P = Stem cells are being tested to grow healthy cells in place of damaged cells
 Q = Patients suffer from limited growth due to broken fat-digesting enzymes
 R = Patients suffer from limited growth due to poor delivery of oxygen to cells and limited ATP energy production
 S = Moderate exercise triggers blood cells to change into a crescent shape

DIRECTIONS: Study the 4 pedigree diagrams (right side) and then label the genotypes for every person in pedigrees #1 & #2. Then answer the ?s below.

2. Which pedigree diagrams show the inheritance of a **recessive** mutation?

3. Which pedigree diagrams show the inheritance of a **dominant** mutation?

4. For Pedigree #1, how many **children** did couple **G & H** have ?

5. For Pedigree #2, how many **sons** did couple **A & B** have ?

6. For Pedigree #1, list all the persons having a **heterozygous genotype**?

7. For Pedigree #2, list all the persons having a **homozygous genotype**?

8. **CIRCLE** all the persons in Pedigrees #1 & #2 who could have more than one possible **genotype**.

9. For Pedigree #1, what is the **phenotype** for person **G**?

10. For Pedigree #2, what is the **phenotype** for person **B**?

11. For Pedigree #1, what is the chance that couple **C & D** will have a healthy child ? (show punnett square)

12. For Pedigree #1, what is the chance that couple **G & H** will have a healthy child ? (show punnett square)

13. For Pedigree #2, what is the chance that couple **H & I** will have a healthy child ? (show punnett square)

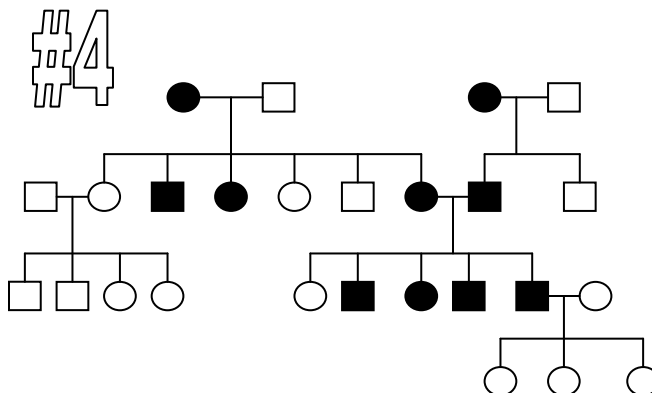
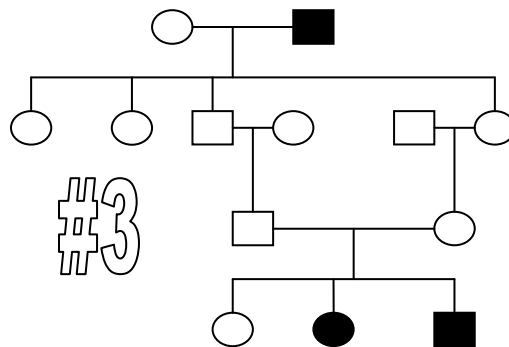
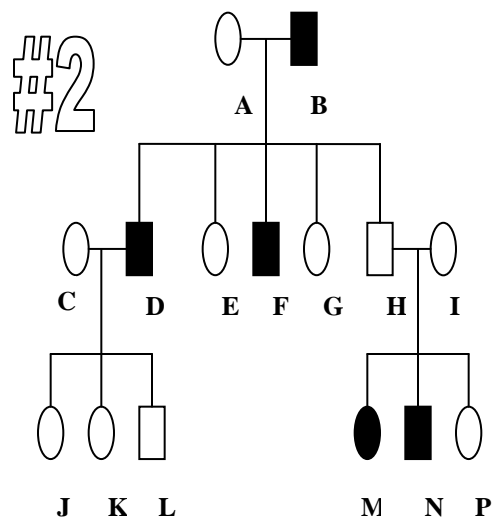
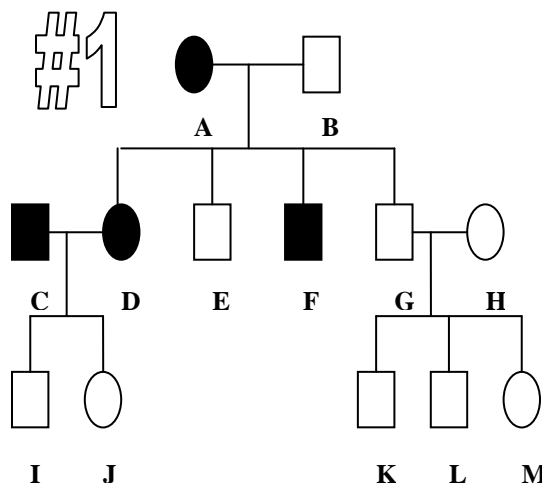

14. Most of the traits expressed in a person's phenotype are determined by alleles located on _____ ?
- Y chromosomes.
 - X chromosomes.
 - autosomal chromosomes (1-22)
 - sex chromosomes.
15. Why are sex-linked recessive conditions more common in men than in women?
- Men acquire two copies of the defective gene during fertilization
 - Men need inherit only one copy of the recessive allele for the condition to be fully expressed
 - Women simply do not develop the disease regardless of their genetic composition
 - The sex chromosomes are more active in men than in women
16. Suppose a person is a carrier for a **autosomal** genetic disorder. Which of the following phrases about this person is true?
- does not have the disorder but can pass it on
 - will develop the disorder only late in life
 - cannot pass the disorder to sons, just daughters
 - the allele cannot be passed to children
17. The allele that causes Duchenne's muscular dystrophy is X-linked recessive. The symbol for the dominant allele is X^D . The symbol for the recessive allele is X^d . If an $X^D X^d$ female and a $X^D Y$ male have children, what percentage of their male offspring would be expected to have muscular dystrophy?
- 0%
 - 50%
 - 75%
 - 100%
18. Because the gene for muscular dystrophy (MD) is located on the X chromosome, it is normally NOT possible for:
- A father with MD to pass the gene on to his daughter
 - A father with MD to pass the gene on to his son
 - A carrier mother to pass the gene on to her son
 - A carrier mother to pass the gene on to her daughter
19. In humans, **sex-linked** diseases like red-green color blindness and muscular dystrophy are ____.
- equally common in both sexes
 - more common in women than men
 - more common in men than women
 - never a health problem for women
20. In humans, **autosomal** traits like dimples, freckles, attached ears, tongue-rolling, and widow's peak are ____.
- equally common in both sexes
 - more common in women than men
 - more common in men than women
 - impossible for women to have
21. Which type of person could be healthy, but still a carrier for a **sex-linked** disease?
- male only
 - female only
 - both males and females
 - neither males nor females could be a carrier
22. Which type of person could be healthy, but still a carrier for an **autosomal** disease?
- male only
 - female only
 - both males and females
 - neither males nor females could be a carrier
23. A child is diagnosed with a rare genetic disease. Neither parent has the disease. How might the child have inherited the disorder?
- The disorder is dominant and was carried by a parent.
 - The disorder is recessive and carried by both parents.
 - The disorder is sex linked and inherited only from the father.
 - The disorder could occur only as a new mutation in the child because neither parent had the disease.

24. A man with blood type B has a daughter who is type A and a son who is type AB. Which of the following is a possible blood phenotype for the mother?
- A
 - O
 - B
 - AB
 - Impossible to determine
25. The gene for red-green color blindness is located on the X-chromosome. Can a father pass on this mutated allele to his daughter? Why or why not?
26. MOM's phenotype can be determined by _____?
- looking at Mom's chromosomes
 - looking at Mom's parents and their traits
 - looking at Mom and her traits
 - looking at Mom's children and their traits

Biologists have discovered a new species of lady bug that comes in three colors: red, yellow, and orange. A cross between red and yellow lady bugs produces orange lady bugs, indicating that body color is determined by two alleles (red & yellow) that are incompletely dominant and blend to produce orange. Lady bugs also have either black or gray dots on their wings, with black being dominant.

27. If red lady bugs with gray dots are crossed with yellow lady bugs homozygous for black dots, what will the genotype and phenotype be for each lady bug in the **first generation (F₁)**?

Genotype: _____

Phenotype: _____

28. Use a 2-Trait Punnett square to determine the chance that a **second generation (F₂)** lady bug from this cross above will be orange with gray dots? _____

Gene notation	___ = _____
	___ = _____
Symbols used	___ = _____
	___ = _____
Parent	MOM = _____
Genotypes	DAD = _____
Mom's egg varieties:	_____
Dad's sperm varieties:	_____

29. In rabbits, black hair (B) is dominant to brown (b) and short hair (S) is dominant to long (s). A female rabbit heterozygous for black, short hair is mated with a male rabbit homozygous for brown, long hair. What is the probability that a bunny will have brown, long hair just like the father? _____ (SHOW YOUR WORK)

Gene notation	___ = _____
	___ = _____
Symbols used	___ = _____
	___ = _____
Parent	MOM = _____
Genotypes	DAD = _____
Mom's egg varieties:	_____
Dad's sperm varieties:	_____
